

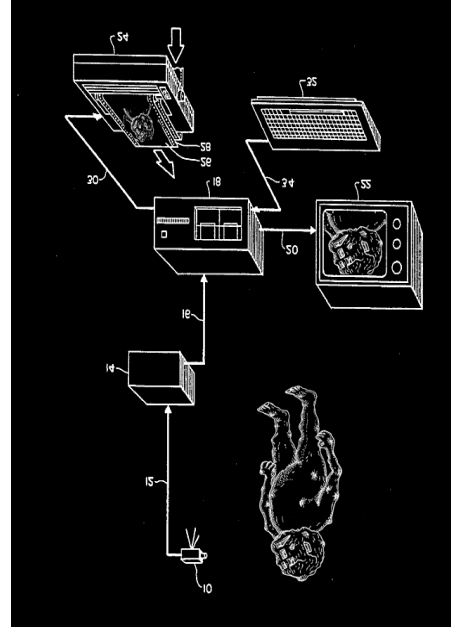

Relatedly, "This fall...An underground ring of superconducting magnets, reaching from Switzerland into France, will smash together subatomic particles at incredible force. Physicists say they're not sure what will emerge from those collisions. They're hunting a mysterious, hypothetical particle called the Higgs boson. It is also possible they will make miniature black holes, or discover new dimensions of space-time;" (transmission intercepted 4/9/07)

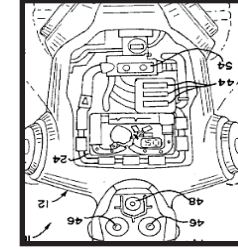

an art of the creative short-circuit. And a process associated with wizards and witches. Glitches as familiars ready at the glitchcraft's side. A muse, a spirit for further beglitching.



also a means of transforming everyday electronics into glitchcraft. Vessels for exploring new worlds. Or,

Timecraft being a time machine in the sci-fi sense, or time-machine inherently involves travelling through time. Circuit-bending is timecraft but

## WEIRD FICTION

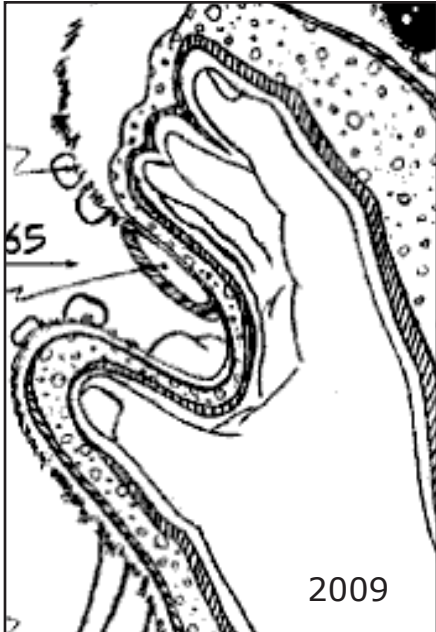

## GLITCHCRAFT

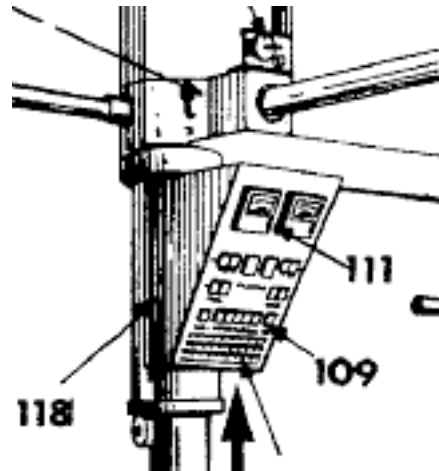

A FICTO-QUIZZICAL MILIEU

Beyond slippage which is the essence of glitch...further afield, to probe the alleged associations with the US space program.

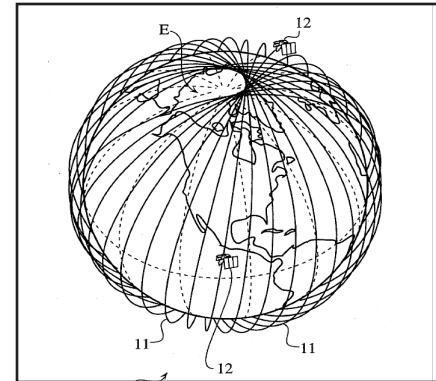

Glitchcraft is crafty for all its possible lines of flight. A neologism hovering betwixt 'n' between meanings, a proto-theory object with trails of attention glimpsed in a simple google search.

The gremlin, if we recall (how could we forget?) is a mischievous cryptid infamous for erring aeroplanes in WWII.

The gremlin is adept at crafting glitches for all manner of vehicle or vessel used for transportation.

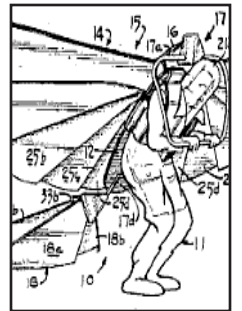
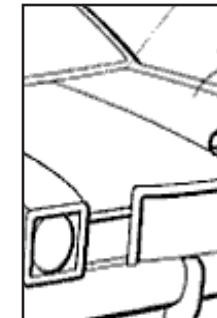

In other words, the gremlin is good at glitching "craft"